

# Pneumatic Blending

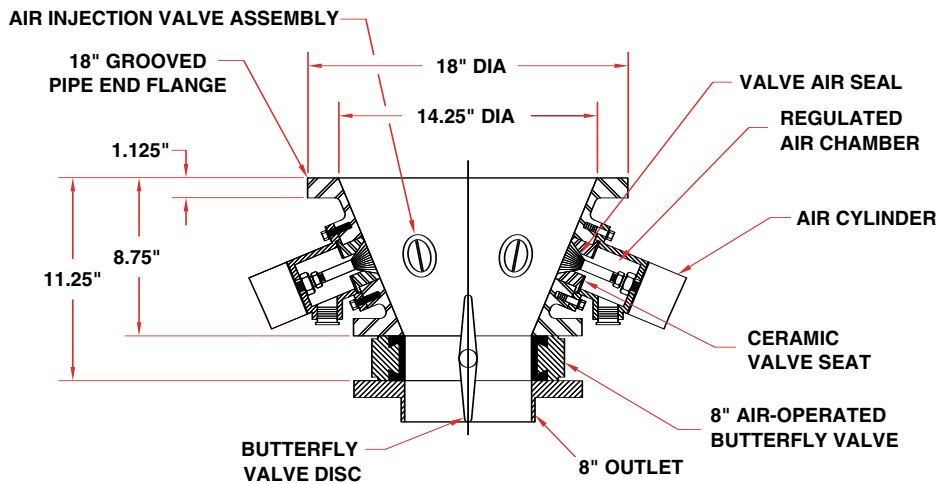



**Quick, Clean, Efficient Blending**

Pneumatic (air) blending is one of the quickest, cleanest, and most efficient methods of achieving homogeneous batches of powdered, granular, and/or abrasive materials. Unlike conventional blenders, a pneumatic blender puts the user in control, providing the ability to customize a blending cycle that will best fit the application.

**Simplified, Low-Maintenance Design**

**NOL-TEC** has further refined the concept of air blending with the design of a reliable, low-maintenance pneumatic blender. This simplified blender is comprised of a casting and six removable air injection valve assemblies which are mounted in a circular pattern on the casting. Because there are virtually no moving parts, maintenance is minimal. All six valve assemblies are externally accessible and can be quickly and easily replaced or repaired on-site.

**Gentle Pulses of Air With Easy Adjustment**

When the valve assemblies are “pulsed,” a piston is forced up, injecting a gentle blast of compressed air into the center of the material at various angles. The material is lifted upward and outward in a continuous circular motion. Blending action is optimized by adjusting the pressure, the “on” and “off” duration, and the frequency of the air pulses.

**Silo Blender Available**

**NOL-TEC** also offers a 32" diameter silo blender. This unit features twelve removable air injection valve assemblies and is ideal for the homogeneous blending of large batches of powdered, granular, and/or abrasive materials in storage silos.

Call today! **NOL-TEC's** in-house test facility is fully equipped to offer complete testing of your pneumatic blending application.

**Key Benefits:**

- Quick, gentle blending
- Ultimate control of blend cycle
- Clean operation
- Low maintenance
- Uses standard plant compressed air

**Optional Features:**

- Custom mounting flanges
- Sanitary, high temperature or USDA dairy dry design
- Interior coatings
- Stainless steel construction
- Explosion proof electrical

**Standard Specifications:**

- Clean, dry air at correct pressure dew point, 80 (min) to 100 (max) PSIG
- 110/120V, 50/60 Hz power required
- 200°F maximum material temperature

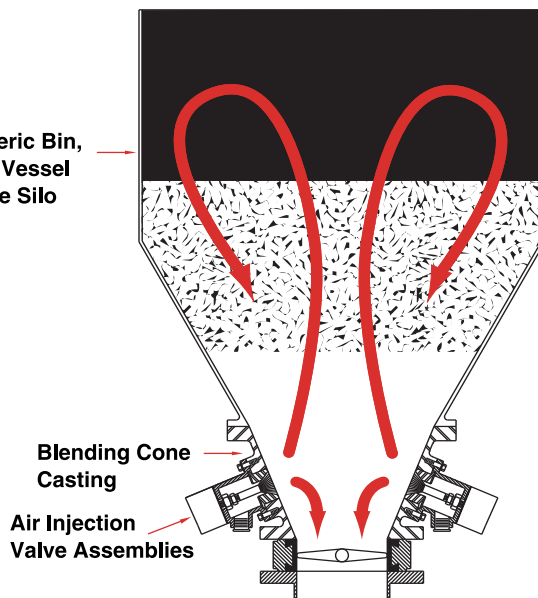

**CORPORATE OFFICE**

Nol-Tec Systems, Inc.  
425 Apollo Drive  
Lino Lakes, MN 55014  
Ph: +1-651-780-8600  
Fx: +1-651-780-4400  
sales@nol-tec.com  
www.nol-tec.com

**REGIONAL SALES OFFICE**

Nol-Tec Systems, Inc.  
901 Blairhill Road, Suite 500  
Charlotte, NC 28217  
Ph: +1-651-780-8600  
Fx: +1-704-529-0139

**REGIONAL SALES OFFICE**

Nol-Tec Systems, Inc.  
Bldg 1000, Suite 155  
5250 E US Highway 36  
Avon, IN 46123  
Ph: +1-317-745-7977  
Fx: +1-317-745-7978

**EUROPEAN OFFICE**

Nol-Tec Europe S.r.l.  
Via Milano, 14  
20064 Gorgonzola (MI)  
Italy  
Ph: +39-02-95-16-875  
Fx: +39-02-95-11-473  
info@nol-teceurope.com  
www.nol-teceurope.com

**CENTRAL ASIA OFFICE**

Nol-Tec (Asia) Pte. Ltd.  
No. 10 Admiralty Street  
#02-14 Northlink Bldg  
Singapore 757695  
Ph: +65-6753-5535  
Fx: +65-6753-5575  
ntasia@nol-tecasia.com.sg