



Model 328 FLUIDIZING BIN BOTTOM

The NOL-TEC fluidizing bin bottom promotes the free flow of powdered or granular materials in storage vessels.

STANDARD FEATURES:

- Three air injection valve assemblies controlled by one solenoid valve for aeration sequencing
- Ceramic valve seat directs air into material at various angles
- Abrasion-resistant urethane valve
- Wear parts replaceable from outside container
- Air controls: manifold, regulator, hoses, and solenoid
- Cone angle approx. 70°

OPTIONAL FEATURES:

- Stainless steel construction
- Interior coatings
- Special mounting flanges
- Individual solenoid valve for aerator sequencing
- Sanitary design
- Explosion-proof design
- High-temperature design

FLUIDIZING BIN BOTTOM		
MODEL	DISCHARGE SIZE	A
328-4-3	4"	27"
328-6-3	6"	24"
328-8-3	8"	21.25"
328-10-3	10"	18.38"
328-12-3	12"	15.56"
328-14-3	14"	16"
328-16-3	16"	16"

SPECIFICATIONS:

- **Weight:** 115 lbs
- **Air:** Clean and dry at correct pressure dew point; 80 PSIG minimum
- **Electrical:** 110-120V; 50/60Hz
- **Temperature:** 200° F

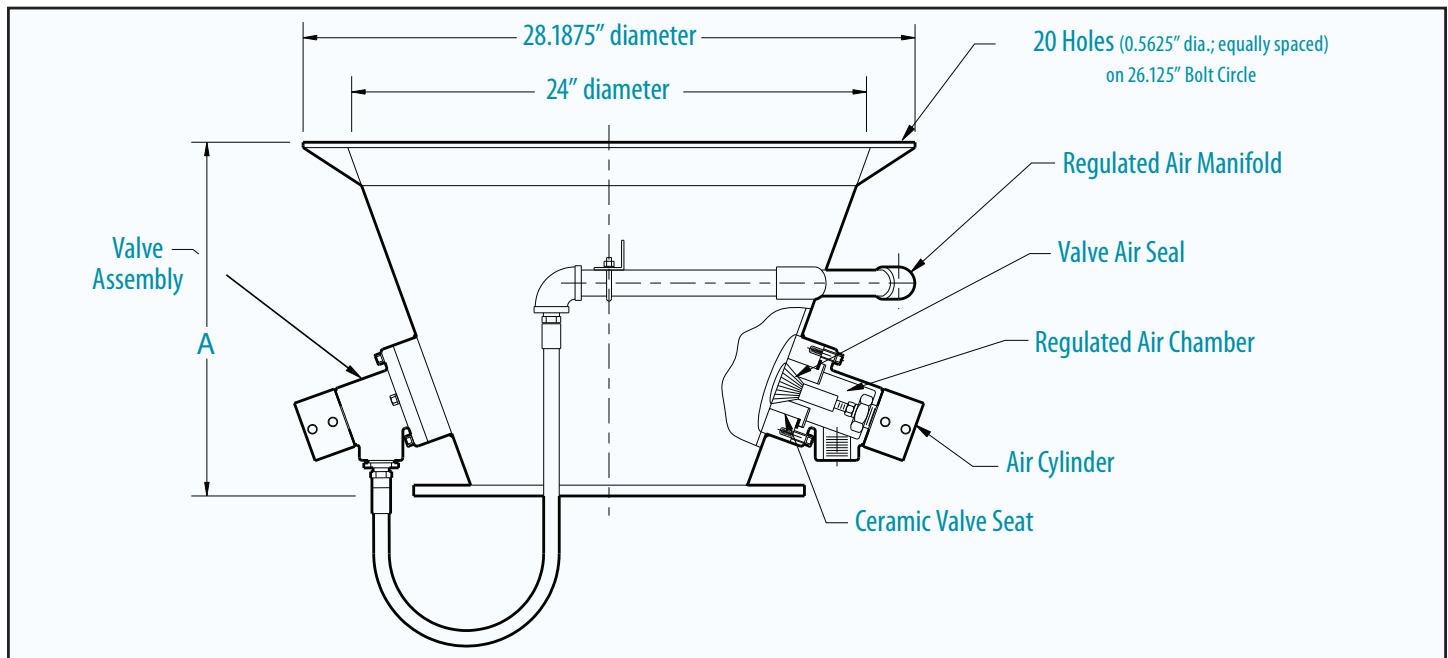

Specifications subject to change without notice.

Nol-Tec Systems, Inc.

425 Apollo Drive

Lino Lakes, MN 55014

(651) 780-8600 • (651) 780-4400 fax

sales@nol-tec.com • www.nol-tec.com