



Model 202

# TRANSPORTER - 45° CONE

*NOL-TEC transporters are designed to provide trouble-free dense phase pneumatic conveying of most materials.*

**STANDARD FEATURES:**

- Heavy-duty design
- Smooth interior
- 45° cone
- Manway
- Erosion allowances on wear surfaces
- Butterfly valve with pneumatic actuator
- Rotatable outlet

**SPECIFICATIONS:**

- **Design pressure:** 90 PSIG
- **Temperature range:** -20° F to +650° F

**OPTIONAL FEATURES:**

- Aeration jets
- Interior coatings
- Multiple inlets
- Stainless steel construction
- Higher pressure and temperature ratings

**CODES:**

- A.S.M.E. Section VIII with National Board registration

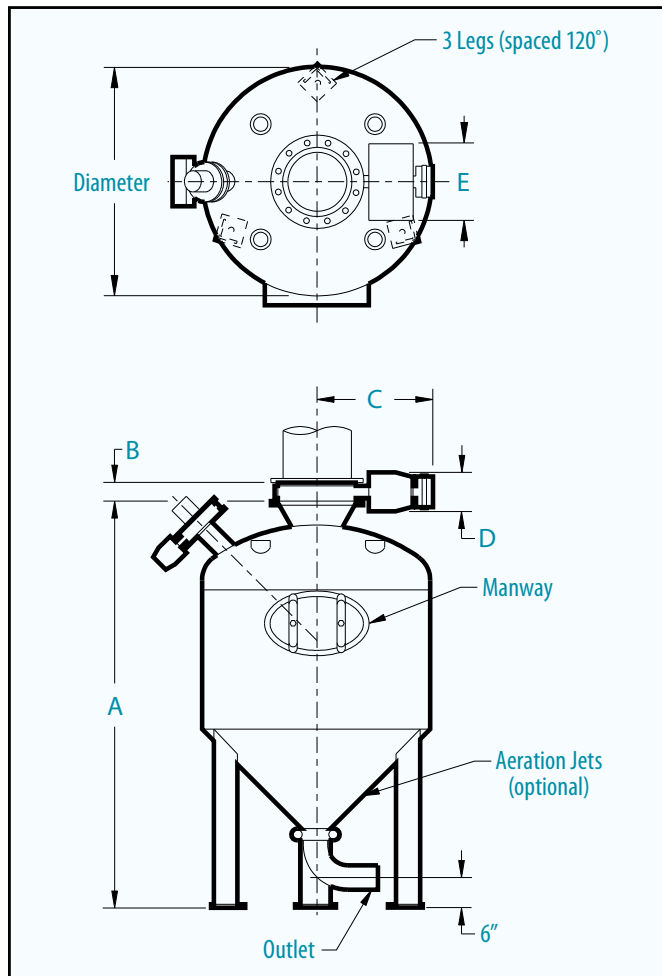

TRANSPORTER				
MODEL	CAPACITY	A	DIAMETER	SHIP WEIGHT
36-45-010	10 ft <sup>3</sup>	4' 8"	3'	900 lbs
42-45-020	20 ft <sup>3</sup>	5' 8"	3' 6"	1,220 lbs
42-45-030	30 ft <sup>3</sup>	7'	3' 6"	1,720 lbs
42-45-040	40 ft <sup>3</sup>	8'	3' 6"	1,890 lbs
54-45-060	60 ft <sup>3</sup>	8' 6"	4' 6"	2,030 lbs
54-45-080	80 ft <sup>3</sup>	9' 6"	4' 6"	2,300 lbs
54-45-100	100 ft <sup>3</sup>	10' 9"	4' 6"	2,570 lbs
72-45-150	150 ft <sup>3</sup>	11'	6'	3,360 lbs
72-45-200	200 ft <sup>3</sup>	12' 9"	6'	3,860 lbs
72-45-250	250 ft <sup>3</sup>	14' 9"	6'	4,360 lbs
96-45-500	500 ft <sup>3</sup>	17'	8'	8,000 lbs
120-45-750	750 ft <sup>3</sup>	18'	10'	10,000 lbs

INLET VALVE					
SIZE	B	C	D	E	SHIP WEIGHT
8"	2.5"	20.5"	6"	10.88"	60 lbs
10"	2.5"	21.25"	6"	10.88"	75 lbs
12"	3"	23.75"	8"	15.75"	150 lbs
16"	4"	26.63"	8"	22"	300 lbs
18"	4.25"	28.25"	8"	22"	335 lbs
20"	6"	29.63"	8"	22"	425 lbs

*Specifications subject to change without notice.*