



Model 208

AIR ACTIVATED GRAVITY CONVEYOR

The NOL-TEC air activated gravity conveyor conveys dry granular or powdered materials in a fully enclosed dust-tight housing using either high or low pressure air.

STANDARD FEATURES:

- 10-gauge construction
- Polyester aeration media
- Adjustable inlet location
- Air inlet in each section
- Inspection opening in each section
- Air controls for high or low pressure

OPTIONAL FEATURES:

- Stainless steel construction
- Stainless steel aeration media
- Flanged inlet and outlet
- Multiple inlets and outlets
- High-temperature design
- Contact Nol-Tec with any special requirements

SPECIFICATIONS:

- **Air:** Compressed plant supply; Positive displacement blower; Clean and dry at correct pressure dew point
- **Temperature (membrane):** 350° F maximum

AIR ACTIVATED GRAVITY CONVEYOR						
SIZE	A	B	C	D	E	F
4	3.75"	4"	6"	8.44"	2.19"	4"
6	5.75"	6"	8"	10.44"	2.19"	6"
8	7.75"	8"	10"	12.44"	2.19"	6"
10	9.75"	10"	12"	14.44"	2.19"	8"
12	11.75"	12"	14"	16.44"	2.19"	8"
14	13.75"	12"	16"	16.44"	2.19"	10"
16	15.75"	12"	18"	16.44"	2.19"	10"
18	17.75"	12"	20"	16.44"	2.19"	12"

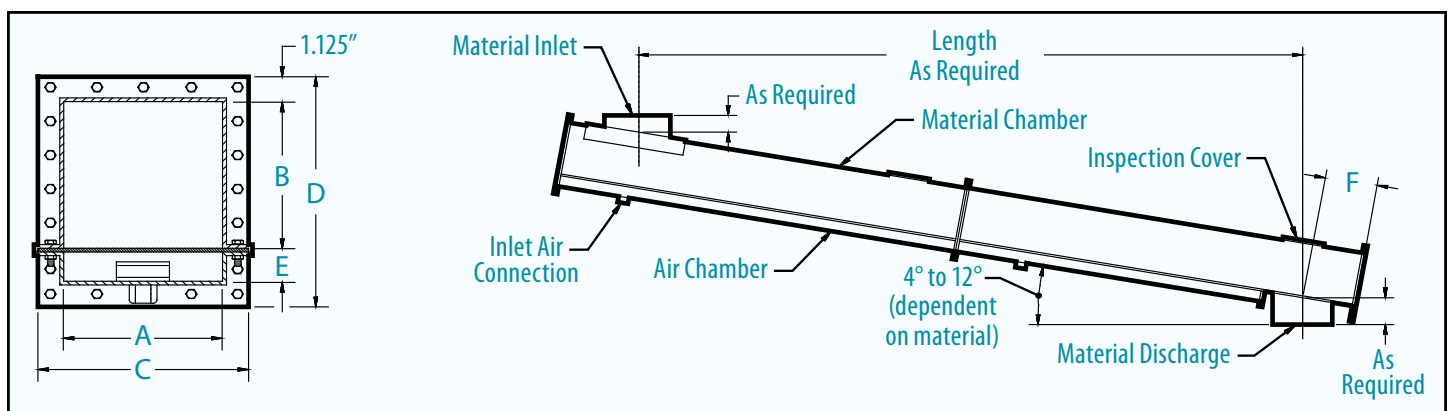

Specifications subject to change without notice.

Nol-Tec Systems, Inc.

425 Apollo Drive

Lino Lakes, MN 55014

(651) 780-8600 • (651) 780-4400 fax

sales@nol-tec.com • www.nol-tec.com