



Models 228 & 232 END & SILO RECEIVERS

NOL-TEC receivers provide long-lasting performance for termination of most pneumatic conveying systems.

STANDARD FEATURES:

- Heavy-duty plate design
- Continuously welded
- Even dispersion of material inside receiving container
- Separation of material and conveying air
- Long-lasting and maintenance-free

OPTIONAL FEATURES:

- Stainless steel construction
- Various pipe schedules
- Grooved or flanged pipe ends
- Rubber coated contact surface
- Mounting flange (Model 228)

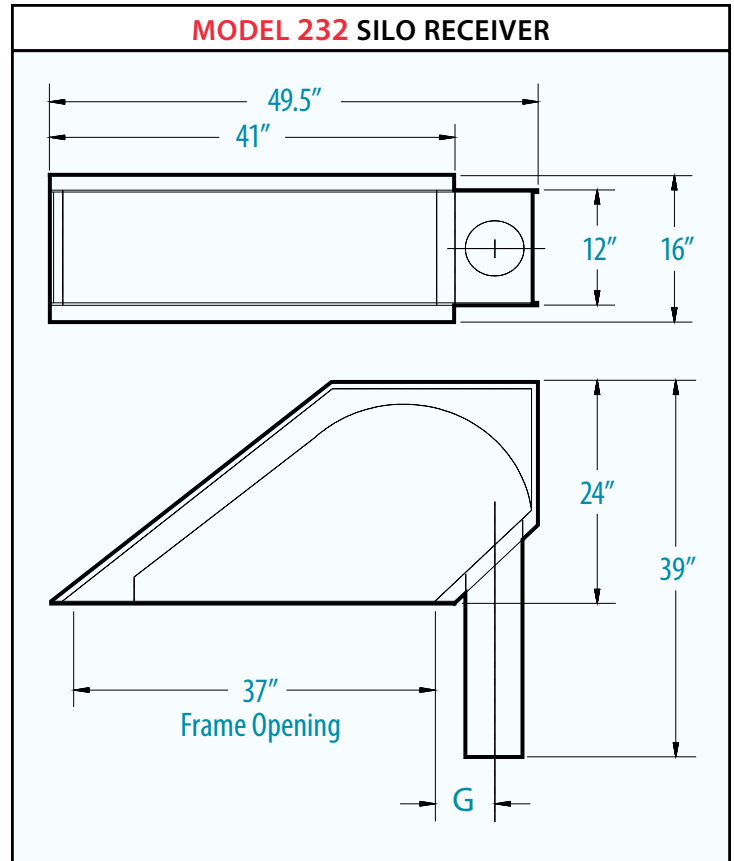
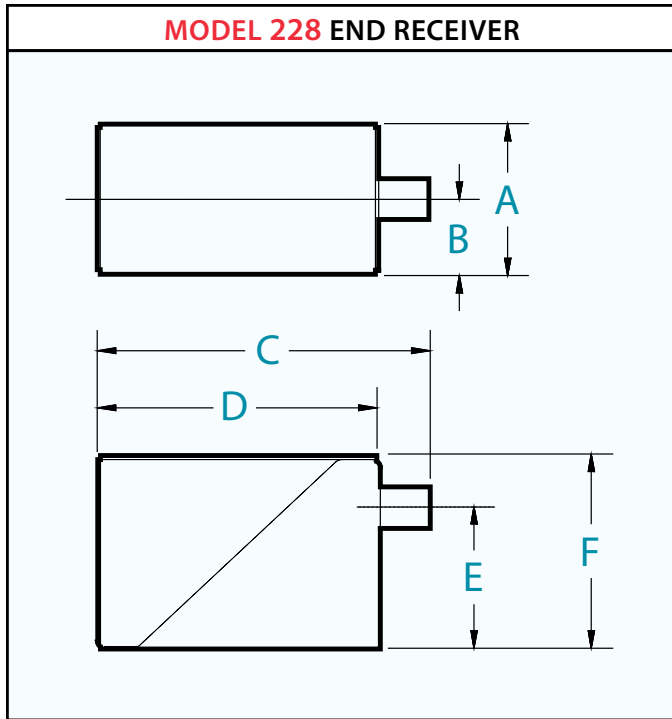

END & SILO RECEIVERS								
PIPE SIZE	A	B	C	D	E	F	G	SHIP WEIGHT
2"	6.38"	3.19"	26.5"	23.38"	14"	18.25"	--	90 lbs
3"	12.5"	6.25"	26.5"	23.38"	14"	18.25"	7.69"	150 lbs
4"	12.5"	6.25"	26.5"	23.38"	14"	18.25"	7.18"	155 lbs
5"	12.5"	6.25"	26.5"	23.38"	14"	18.25"	6.69"	160 lbs
6"	12.5"	6.25"	26.5"	23.38"	14"	18.25"	6.12"	165 lbs
8"	18.75"	9.38"	42.75"	36.75"	15"	22.5"	--	325 lbs
10"	18.75"	9.38"	42.75"	36.75"	15"	22.5"	--	350 lbs

Specifications subject to change without notice.

Nol-Tec Systems, Inc.
 425 Apollo Drive
 Lino Lakes, MN 55014
 (651) 780-8600 • (651) 780-4400 fax
 sales@nol-tec.com • www.nol-tec.com