

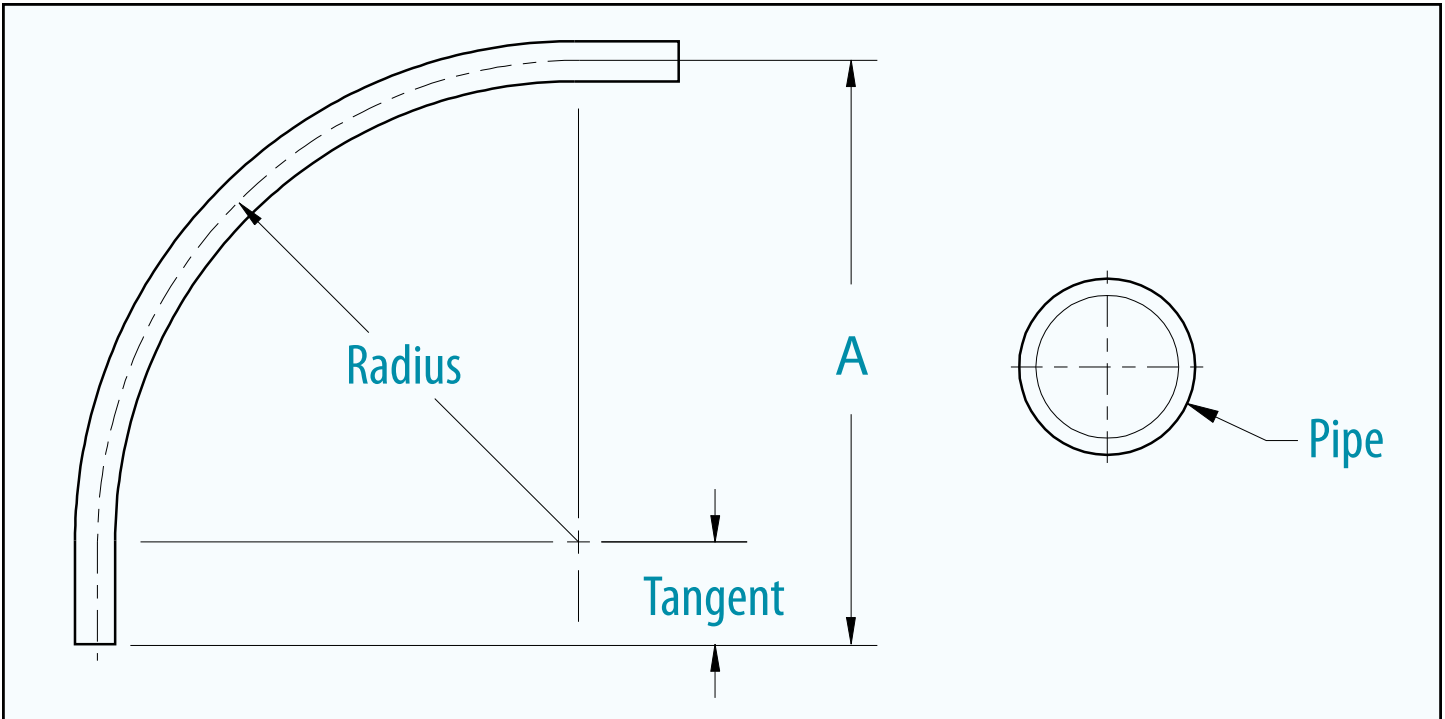

Model 240 STANDARD 90° PIPE BENDS

NOL-TEC long radius pipe bends are available in carbon steel, stainless steel, or aluminum construction and are ideally suited for many dense phase pneumatic conveying applications.



STANDARD 90° PIPE BENDS					
SIZE*	SCHEDULE	RADIUS	TANGENT	A	WEIGHT
2"	40	24"	4"	28"	14 lbs
2"	80	24"	4"	28"	20 lbs
3"	40	24"	6"	30"	32 lbs
3"	80	24"	6"	30"	43 lbs
4"	40	36"	8"	44"	66 lbs
4"	80	36"	8"	44"	91 lbs
5"	40	48"	10"	58"	117 lbs
5"	80	48"	10"	58"	166 lbs
6"	40	48"	12"	60"	157 lbs
6"	80	48"	12"	60"	237 lbs
8"	40	60"	16"	76"	301 lbs
8"	80	60"	16"	76"	457 lbs
10"	40	50"	20"	70"	400 lbs
10"	80	50"	20"	70"	540 lbs

Specifications subject to change without notice.

*Available in larger sizes.

Nol-Tec Systems, Inc.

425 Apollo Drive
Lino Lakes, MN 55014
(651) 780-8600 • (651) 780-4400 fax
sales@nol-tec.com • www.nol-tec.com