



Model 244 BLENDING CONE

The NOL-TEC blending cone homogeneously blends dry materials in pneumatic transporters or atmospheric bins.

STANDARD FEATURES:

- Six air injection valve assemblies
- Single solenoid valve sequences air injection valve assemblies
- Ceramic valve seat directs air into material at various angles
- Abrasion-resistant urethane valve seal
- Non-restrictive discharge valve with positive position indicator
- Wear parts are replaceable without removing blending cone

OPTIONAL FEATURES:

- Individual air injection solenoid valves for sequential valve actuation

OPTIONAL FEATURES: (continued)

- Interior coatings
- Stainless steel construction
- Explosion-proof electrical
- Special mounting flange
- Sanitary design
- High-temperature design

SPECIFICATIONS:

- **Weight:** 175 lbs
- **Air:** Clean and dry at correct pressure dew point; 80 PSIG minimum
- **Electrical:** 110-120V; 50-60Hz
- **Temperature:** 200° F

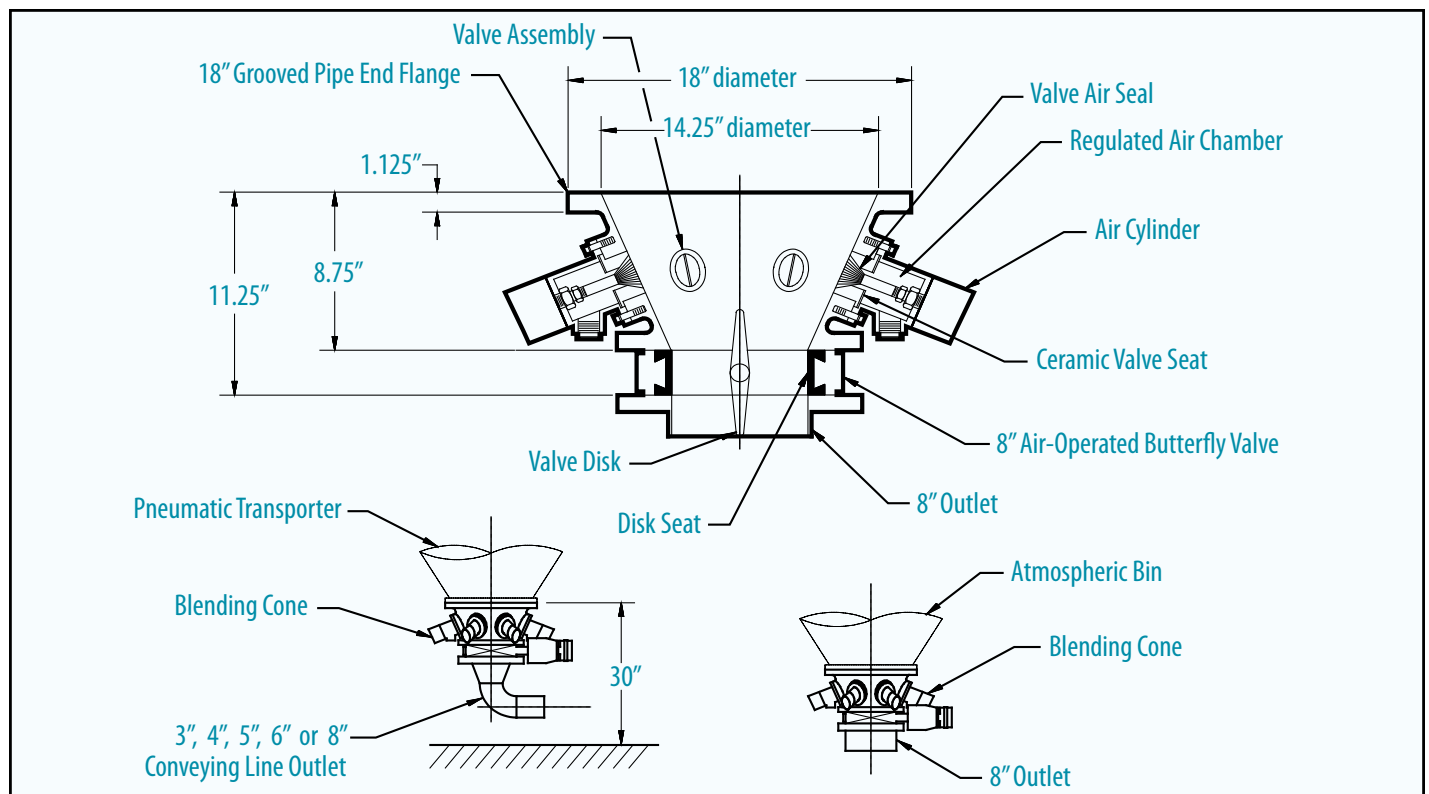

Specifications subject to change without notice.

Nol-Tec Systems, Inc.

425 Apollo Drive

Lino Lakes, MN 55014

(651) 780-8600 • (651) 780-4400 fax

sales@nol-tec.com • www.nol-tec.com