



# Model 256 MANUAL BAG DUMP STATION

The NOL-TEC manual bag dump is a complete work station equipped with an exhauster fan, cartridge dust collector, and collecting hopper.

## STANDARD FEATURES:

- Heavy-duty mild steel construction
- Compact design
- Easy filter access
- Heavy-duty filter media
- Manual cartridge cleaning
- 100% material recovery

## OPTIONAL FEATURES:

- Hopper aeration
- Self-cleaning timer
- Stainless steel construction
- Differential pressure gauge
- Interior coatings
- Extended work surface

## OPTIONAL FEATURES: (continued)

- Special discharge flange
- Drum dump hopper
- Door

## SPECIFICATIONS:

- **Hopper capacity:** 5 ft<sup>3</sup>
- **Filter area:** 180 ft<sup>2</sup>
- **Air:** Clean and dry at correct pressure dew point; 80 PSIG minimum
- **Dust capture velocity:** 200 FPM
- **Exhauster:** 850 CFM; 1.5 HP; 220/440V; 3/60Hz; T.E.F.C.

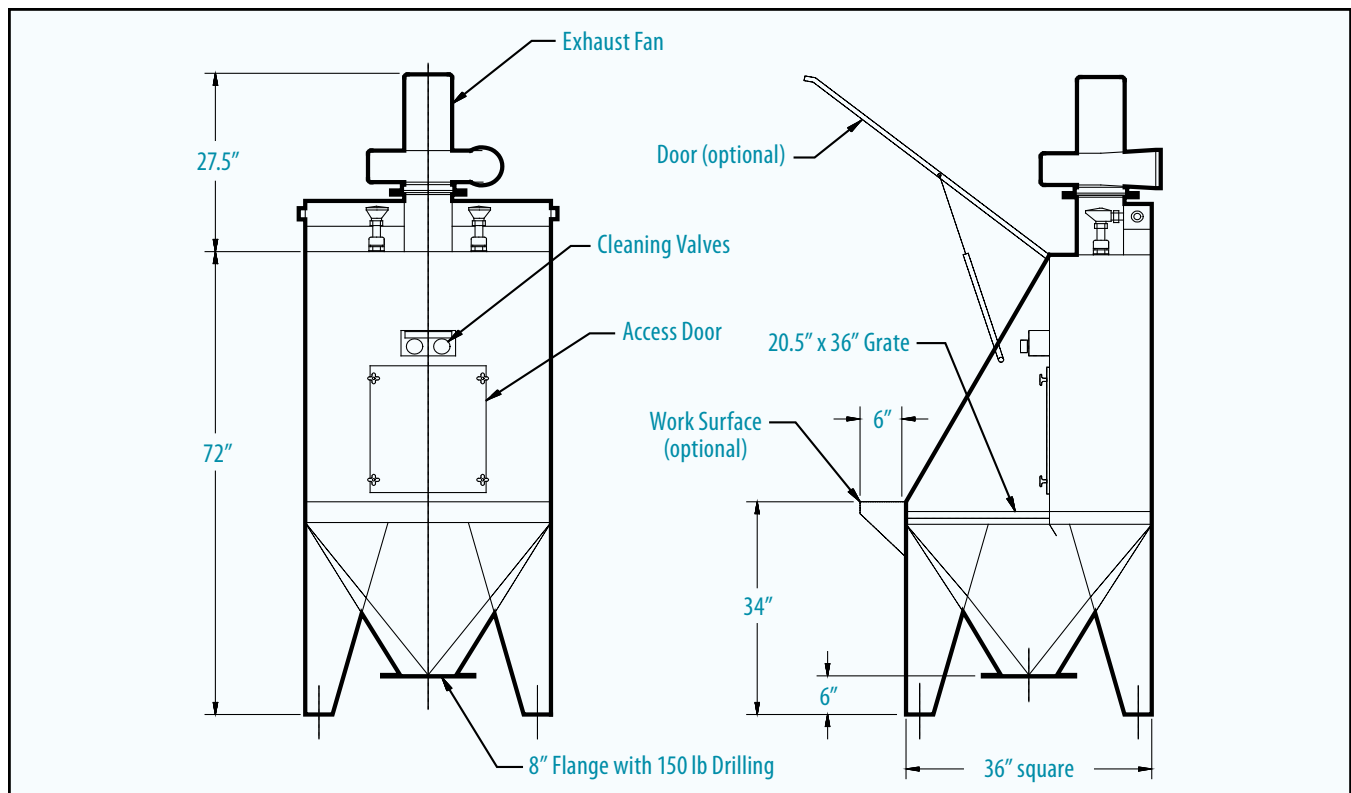

Specifications subject to change without notice.

**Nol-Tec Systems, Inc.**

425 Apollo Drive

Lino Lakes, MN 55014

(651) 780-8600 • (651) 780-4400 fax

sales@nol-tec.com • www.nol-tec.com