

VACUUM / PRESSURE BLOWER PACKAGE MODEL 258

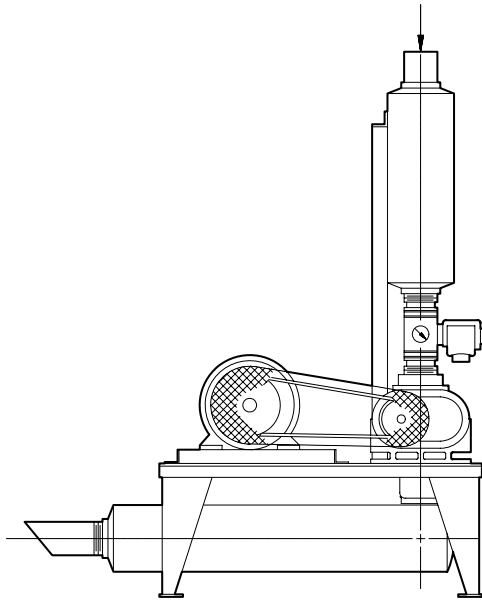

VACUUM

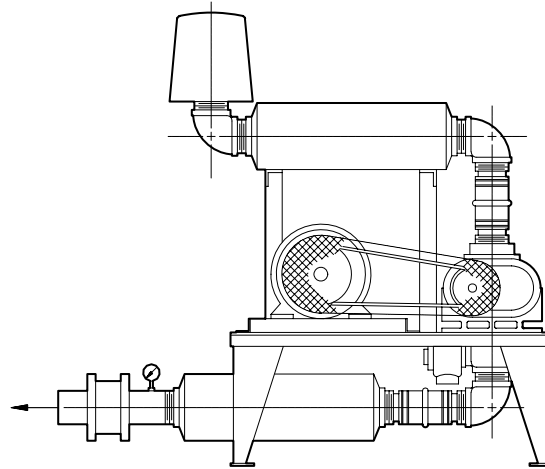

PRESSURE

STANDARD FEATURES:

- Heavy-duty structural base
- Adjustable motor rails
- Inlet filter (pressure only)
- V-belt drive
- Enclosed belt guard with easily detachable front
- Flexible connections
- Relief valves
- Silencers designed for blower
- Check valve assembly (pressure only)
- Silencer support mounts
- Pressure/Vacuum gauge

OPTIONAL FEATURES:

- Sanitary base
- Stainless construction
- Sound enclosures
- Severe duty motors
- Pressure/Vacuum switch
- Temperature switch
- Aftercooler
- Vibration isolators
- Inline filter (vacuum)

258-06-03



5.022.SALE.01.18.07.01

Specifications subject to change without notice.