



Model 331

TOP REMOVAL DUST COLLECTOR

The NOL-TEC top removal dust collector effectively filters dust laden air created by pneumatic conveying systems or other processes.

STANDARD FEATURES:

- 12-gauge continuous welded construction
- Reinforced housing
- Venturi reverse jet cleaning
- Solid state electronic timer
- Continuous cleaning
- Magnehelic gauge
- Bird screen and weatherboard
- External access to filter element

OPTIONAL FEATURES:

- Stainless steel construction
- Variety of filter bag materials
- Variety of filter cartridge materials and types
- Dirty air housing extensions
- Exhauster
- Explosion-proof design
- High-temperature design

SPECIFICATIONS:

- **Air:** Clean and dry at correct pressure dew point; 80 PSIG minimum
- **Electrical:** 110-120V; 50/60Hz
- **Temperature (timer):** 40° F to 150° F
- **Temperature (polyester bags):** 270° F
- **Temperature (polyester cartridges):** 150° F

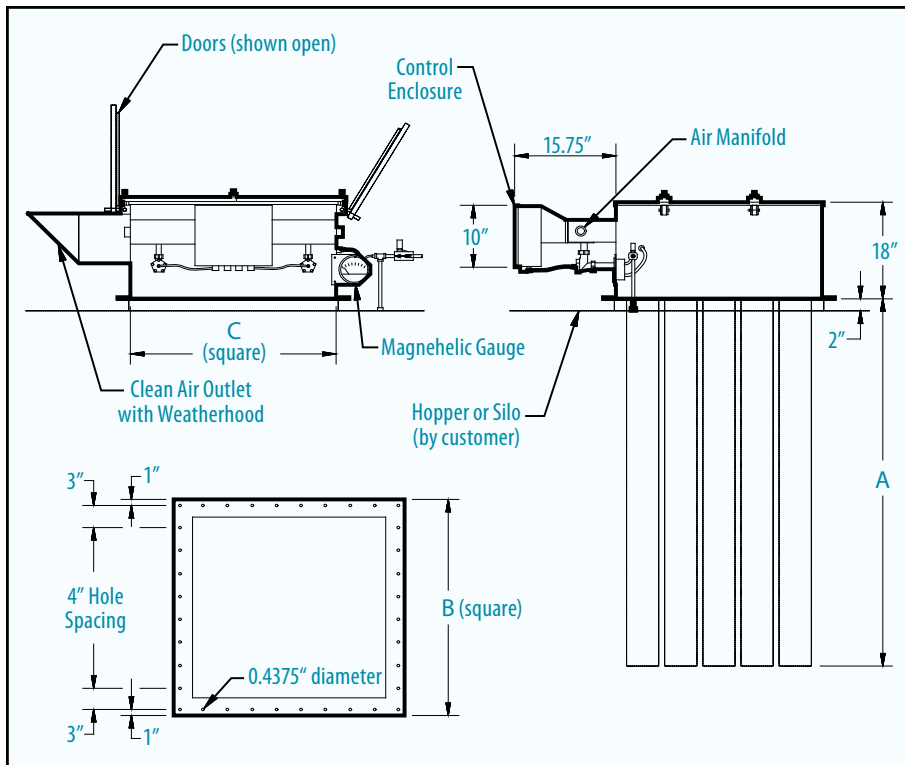

BAG MODELS

MODEL	FILTER AREA	A	B	C
36-TRB-9	41 ft ²	3' 2"	28"	24"
60-TRB-9	68 ft ²	5'	28"	24"
84-TRB-9	95 ft ²	7' 2"	28"	24"
36-TRB-16	72 ft ²	3' 2"	36"	32"
60-TRB-16	120 ft ²	5'	36"	32"
84-TRB-16	168 ft ²	7' 2"	36"	32"
60-TRB-25	188 ft ²	5'	44"	40"
84-TRB-25	263 ft ²	7' 2"	44"	40"
60-TRB-36	270 ft ²	5'	52"	48"
84-TRB-36	378 ft ²	7' 2"	52"	48"
60-TRB-49	368 ft ²	5'	60"	56"
84-TRB-49	515 ft ²	7' 2"	60"	56"
60-TRB-64	480 ft ²	5'	68"	64"
84-TRB-64	672 ft ²	7' 2"	68"	64"
84-TRB-81	851 ft ²	7' 2"	76"	72"
84-TRB-100	1,050 ft ²	7' 2"	84"	80"

CARTRIDGE MODELS

MODEL	FILTER AREA	A	B	C
18-TRC-9	135 ft ²	18"	28"	24"
36-TRC-9	270 ft ²	36"	28"	24"
18-TRC-16	240 ft ²	18"	36"	32"
36-TRC-16	480 ft ²	36"	36"	32"
18-TRC-25	375 ft ²	18"	44"	40"
36-TRC-25	750 ft ²	36"	44"	40"
18-TRC-36	540 ft ²	18"	52"	48"
36-TRC-36	1,080 ft ²	36"	52"	48"
36-TRC-49	1,470 ft ²	36"	60"	56"
36-TRC-64	1,920 ft ²	36"	68"	64"
36-TRC-81	2,430 ft ²	36"	76"	72"
36-TRC-100	3,000 ft ²	36"	84"	80"

Nol-Tec Systems, Inc.

425 Apollo Drive

Lino Lakes, MN 55014

(651) 780-8600 • (651) 780-4400 fax

sales@nol-tec.com • www.nol-tec.com

Specifications subject to change without notice.