

BULK BAG UNLOADER

HOIST LOADING MODEL 348

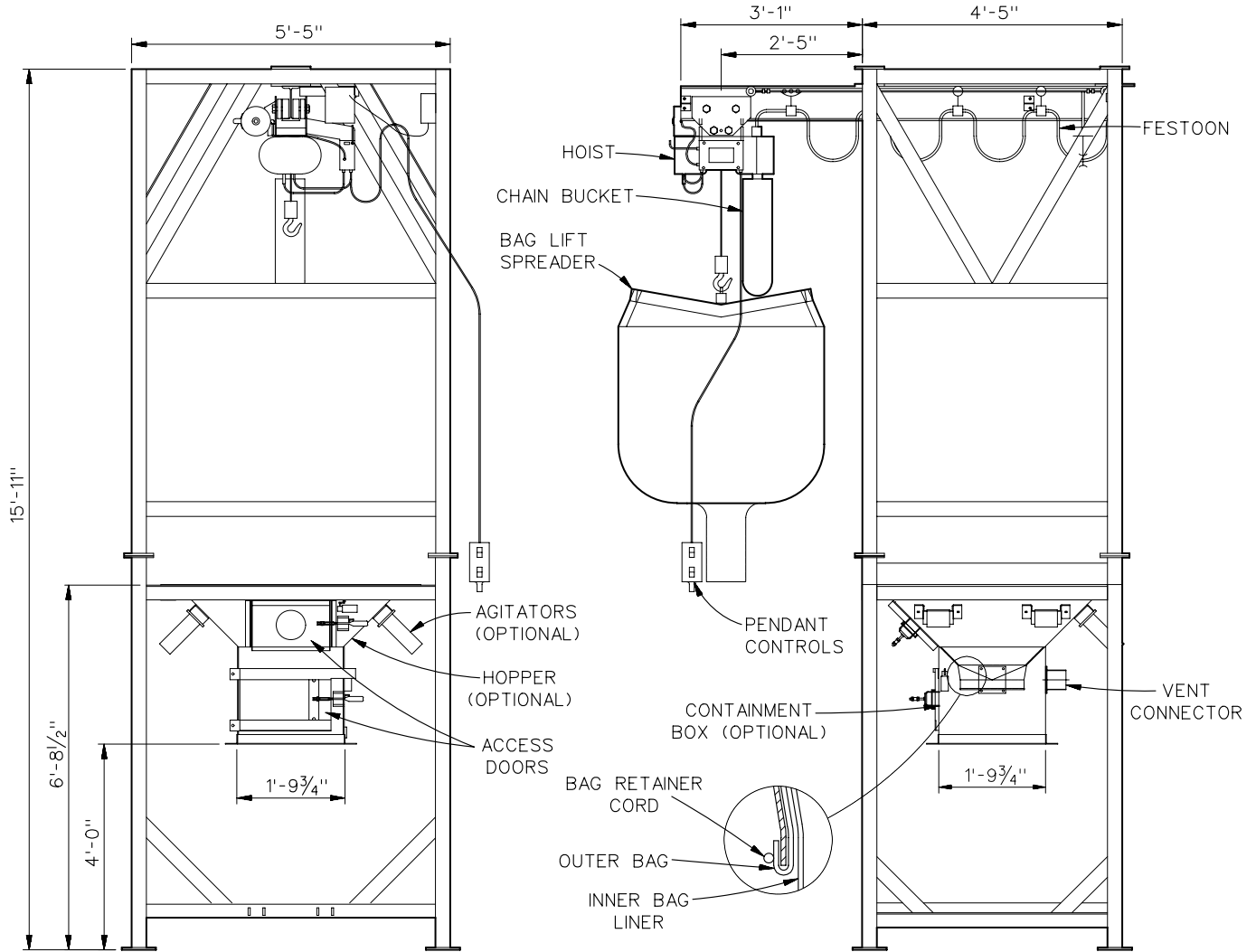

STANDARD FEATURES:

- Heavy-duty mild steel construction
- "Modular" design
- 4,000 lb. rated capacity
- Bag lift spreader

STANDARD OPTIONS:

- Additional height
- 1 or 2 ton electric hoist with:
 - * 16 fpm lift speed
 - * Pendant controls
 - * Chain bucket and festooning
- Power trolley (30 fpm travelspeed)
- Containment hopper/access box with:
 - * 46" X 46" top opening
 - * (2) Bag spout access doors
 - * Spout tie-off with retainer cord
 - * Vent connection
- Pneumatic bag agitators with:
 - * (5) air cylinders
 - * Solenoids to control agitation
 - * Sequence timer in Nema 12 Enclosure

ADDITIONAL OPTIONS:

- Custom units per application
- Transition hoppers
- Discharge feeders
- Dust suppression
- Stainless contact surfaces
- Stainless construction
- Contact NOL-TEC with your special requirements

SPECIFICATIONS:

- 80 PSIG clean-dry-air at correct pressure dew point
- 110v/1Ph/60Hz power required for agitator control
- 230/460/3Ph/50/60hz for hoist & trolley

348-06-03



Specifications subject to change without notice.