

BULK BAG UNLOADER

FORKLIFT LOADING MODEL 349

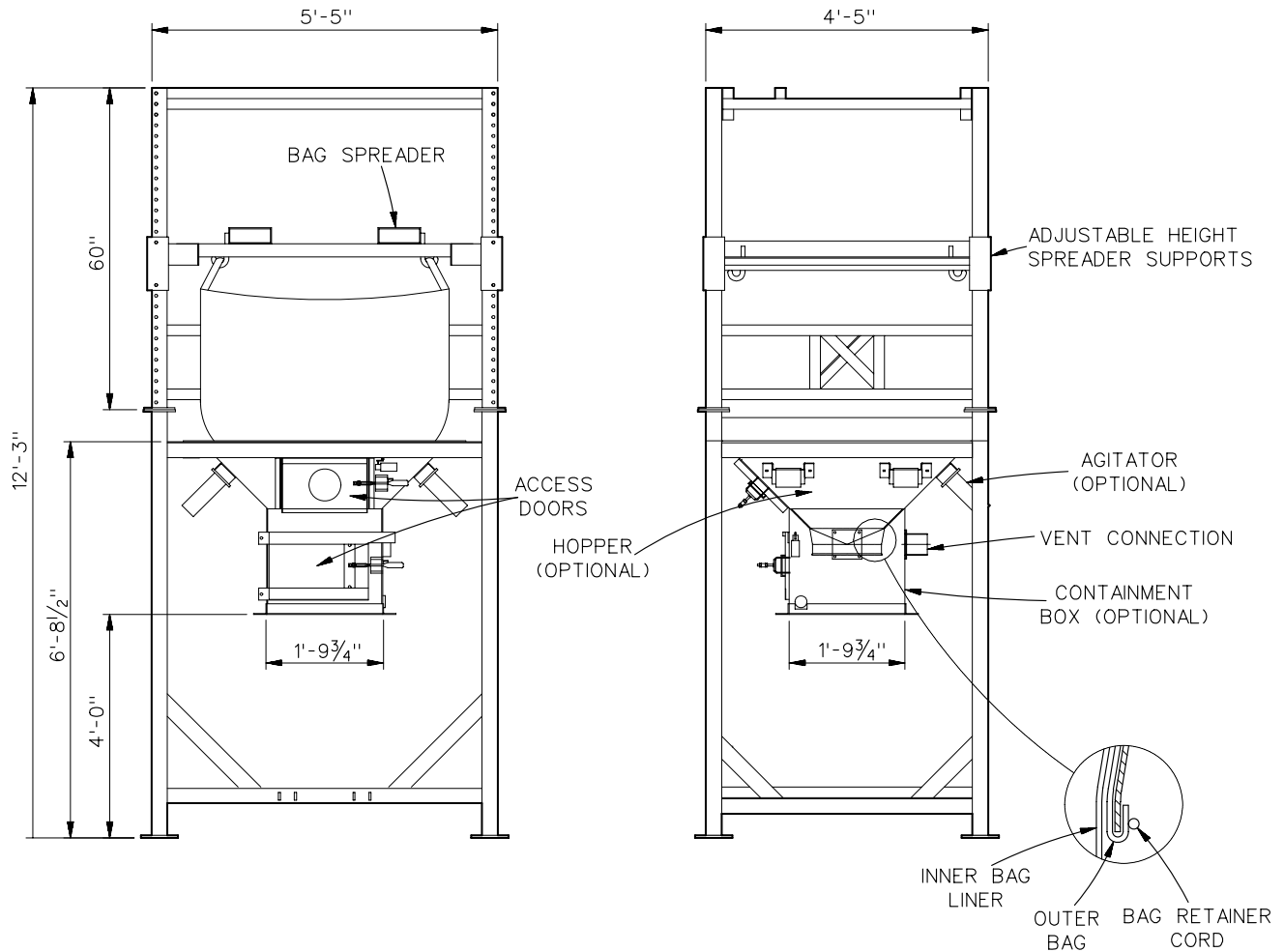

STANDARD FEATURES:

- Heavy-duty mild steel construction
- "Modular" design
- Adjustable height for bag spreader support
- Up to 4,000 lb. bag weight

STANDARD OPTIONS:

- Additional height
- Containment hopper/access box with:
 - * 46" X 46" top opening
 - * (2) Bag spout access doors
 - * Spout tie-off with retainer cord
 - * Vent connection
- Pneumatic bag agitators with:
 - * (5) air cylinders
 - * Solenoids to control agitation
 - * Sequence timer in Nema 12 Enclosure

ADDITIONAL OPTIONS:

- Custom units per application
- Transition hoppers
- Discharge feeders
- Dust suppression
- Stainless contact surfaces
- Stainless construction
- Contact NOL-TEC with your special requirements

SPECIFICATIONS:

- 80 PSIG clean-dry-air at correct pressure dew point
- 115v/1Ph/60Hz power required for agitator control