



Model 357A USDA-ACCEPTED AERATOR

The NOL-TEC USDA-accepted aerator for dry dairy applications effectively aerates or dislodges materials in silos, bins, and chutes.

STANDARD FEATURES:

- Stainless steel valve seat directs air into material at various angles
- Adapter fitting for bin wall designed for cone angle and size
- USDA-3A-compliant o-rings and gaskets
- External replacement of wear parts
- Ferruled valve manifold connection for regulated air
- Ra32 finish (or better) on product contact surfaces

OPTIONAL FEATURES:

- Individual solenoid valve for sequencing
- Explosion-proof electrical

SPECIFICATIONS:

- **Aeration Air:** Dry and filtered to USDA standards; 80 PSIG regulated to required pressure
- **Control Air:** Clean and dry at correct pressure dew point; 80 PSIG minimum
- **Electrical:** 110-120V; 50-60Hz
- **Temperature:** 200° F maximum
- **Weight:** 15 lbs

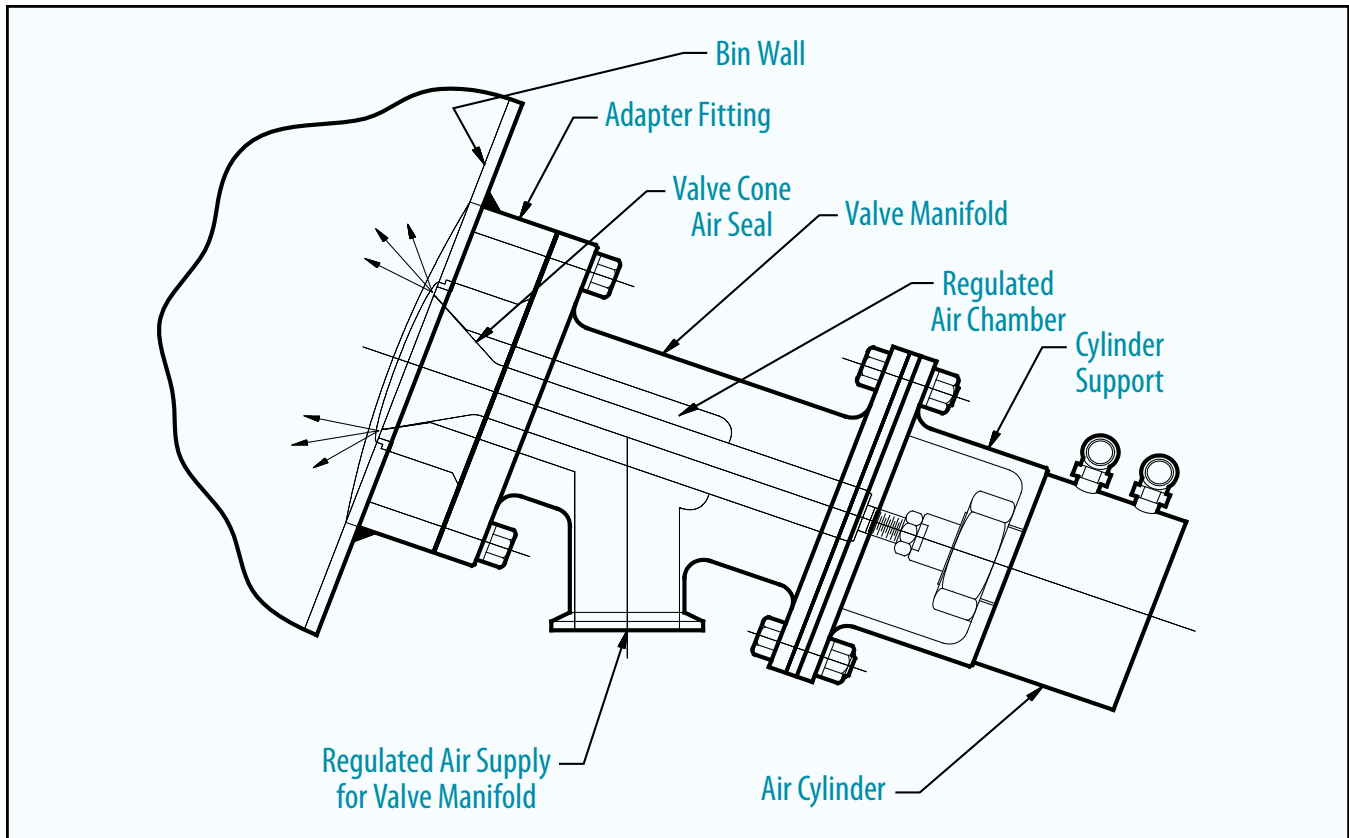

Specifications subject to change without notice.

Nol-Tec Systems, Inc.

425 Apollo Drive

Lino Lakes, MN 55014

(651) 780-8600 • (651) 780-4400 fax

sales@nol-tec.com • www.nol-tec.com