



## Model 362 USDA-ACCEPTED BULK BAG FILLER

The NOL-TEC USDA-accepted bulk bag filler is a safe and effective work station for volumetrically loading bulk bags in dry dairy or sanitary applications.

### STANDARD FEATURES:

- Heavy-duty 304 stainless steel construction
- Ra32 finish on product contact surfaces
- Leg-free design
- Hinged fill spout clamp
- Quick-clean design
- Four hooks for manual bag hanging

### OPTIONAL FEATURES:

- Various fill spout diameters
- Scale base with controls

### OPTIONAL FEATURES: (continued)

- Various spool lengths for elevation adjustment
- Flexible connector
- Control stand

### SPECIFICATIONS:

- **Air:** Compressed; Clean and dry at correct pressure dew point; 80 PSIG minimum
- **Electrical:** 110V; 1 PH; 60Hz

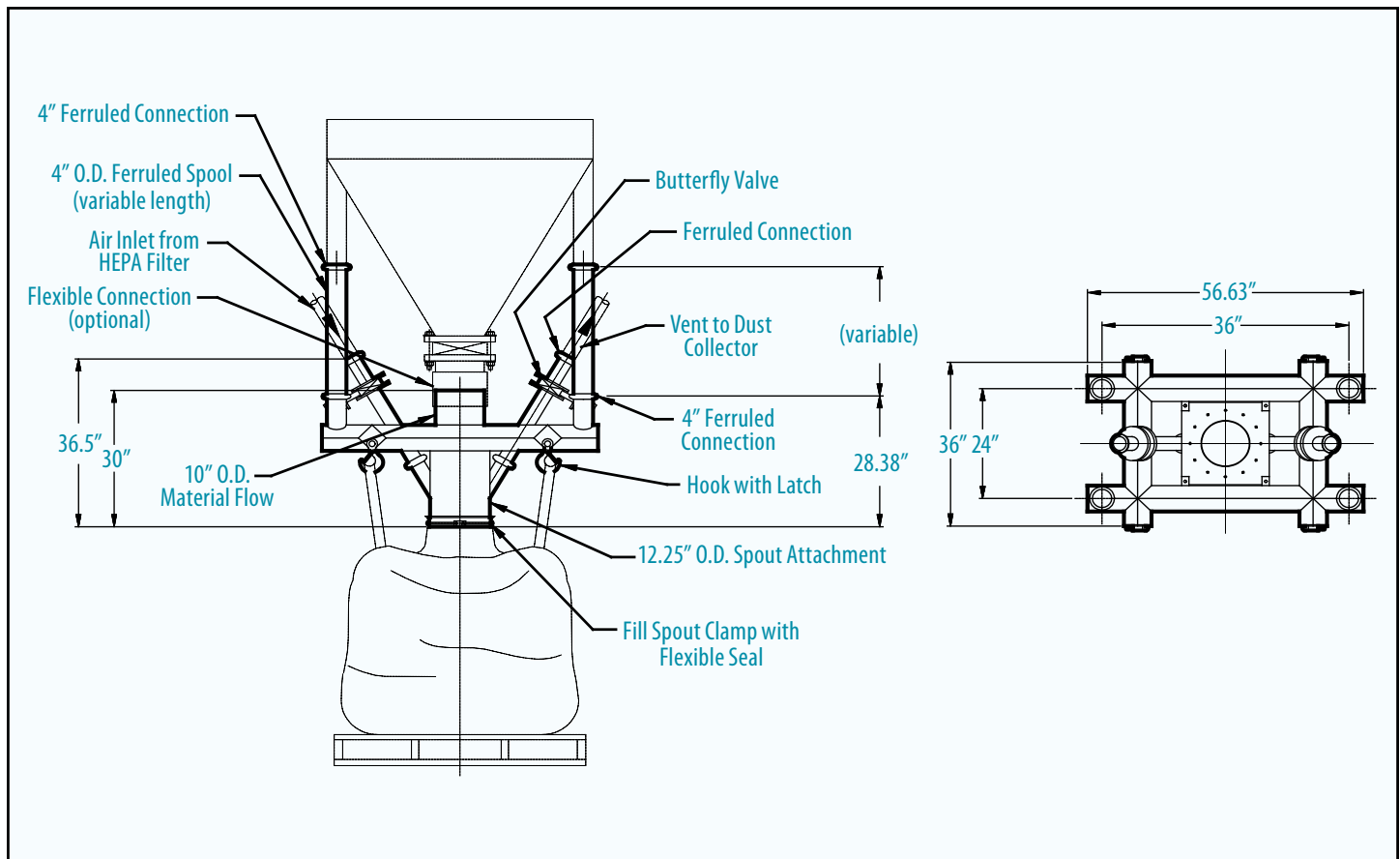

Specifications subject to change without notice.

**Nol-Tec Systems, Inc.**

425 Apollo Drive

Lino Lakes, MN 55014

(651) 780-8600 • (651) 780-4400 fax

sales@nol-tec.com • www.nol-tec.com