



Model 363 USDA AERATOR

The NOL-TEC USDA aerator effectively promotes the free flow of powdered or granular materials and fluidizes silos, bins, or chutes in dry dairy pneumatic conveying applications.

STANDARD FEATURES:

- Materials meet FDA 21 CFR regulations and 3-A Standards 18-XX and 20-XX
- Replaceable disk filter
- Quick removal for cleaning

OPTIONAL FEATURES:

- Pressure regulator
- Flow control valve
- Manifold for pressure and flow control of multiple units

SPECIFICATIONS:

- **Air Requirements:** Clean and dry at correct pressure dew point; Regulated pressure; Flow control with needle valve
- **Design temperature:** -20° F to +180° F
- **Design pressure:** 80 PSIG maximum
- **Nominal pressure:** 20 to 30 PSIG

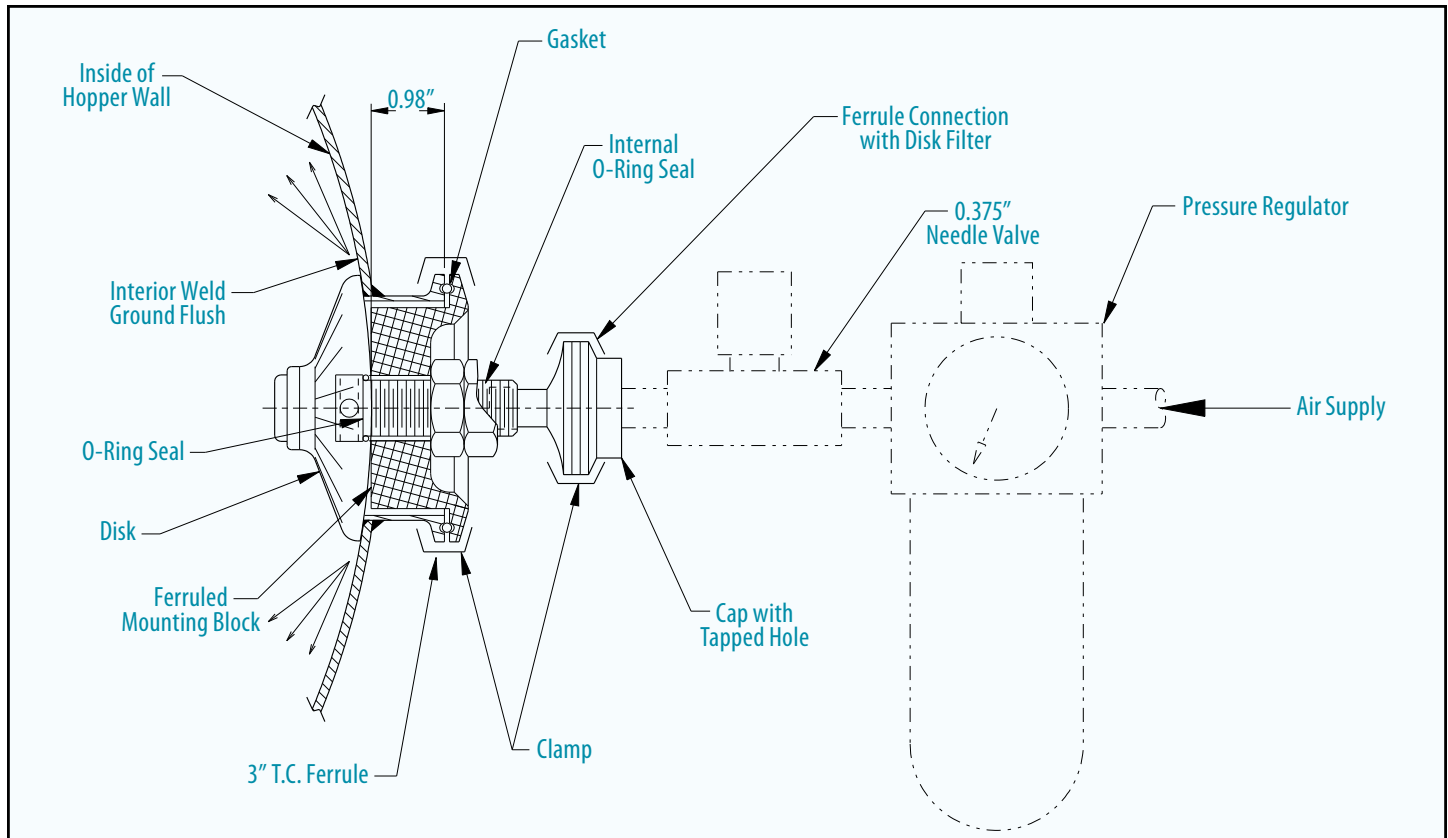

Specifications subject to change without notice.

Nol-Tec Systems, Inc.

425 Apollo Drive

Lino Lakes, MN 55014

(651) 780-8600 • (651) 780-4400 fax

sales@nol-tec.com • www.nol-tec.com